

Eralle

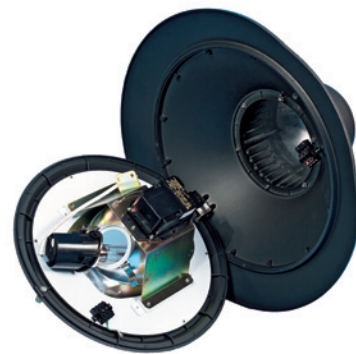

CARACTÉRISTIQUES MÉCANIQUES / MECHANICAL CHARACTERISTICS

Châssis et capot en aluminium injecté, phosphaté et thermolaqué, verre bombé trempé.

Supporting frame and frame made of die cast aluminium, thermo-varnished with polyester dust, rounded hardened glass.



Étanchéité / Protection : IP 66



Finition / Finish :
Peinture polyester selon nuancier RAL
Polyester paint according to RAL color chart



Poids / Weight : 13 / 15



Compatible / Compatible LED



Montage sommital / Hanging assembly :
27 PG mâle / Male PG 27



La ligne classique de l'Eralle évoque subtilement la lampe d'antan. Elle emprunte les codes du passé tout en les réinventant pour les insérer dans un contexte urbain ou rural.

The classic line of Eralle subtly evokes the old day's lamp. It borrows the codes of the past while reinventing them for inclusion in an urban and rural modern-day context.

MAINTENANCE / MAINTENANCE

Le support vasque s'ouvre par une vis quart de tour.
La platine support appareillage est amovible sans outils.
Le support douille, doté d'une équerre réglable, est constitué de matériaux isolants auto-extinguibles à haute résistance thermique et mécanique. Il se démonte manuellement, aisément et sans outil, et se règle en longueur et en hauteur.



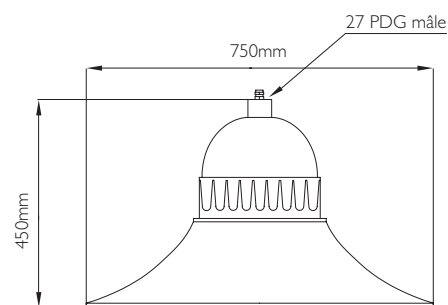

The optic cover support opens with a quarter-turn screw.
The pad support apparatus is removable without tools.
The socket cap, which has an adjustable brace, is made of insulating and fire-proof materials, offering extreme heat and mechanical resistance. It can be dismantled by hand easily without the use of tools and adjustable in length and height.



CARACTÉRISTIQUES ÉLECTRIQUES / ELECTRICAL CHARACTERISTICS



Classe 1 ou 2 / Class 1 or 2

Sodium Haute Pression	Cosmo White	Iodures Métalliques	Eclairage LED
			
70 - 100 - 150 - 250 W	45 - 60 - 90 W	70 - 100 W	40 - 60 W

